

Počítačová grafika III – Irradiance Caching

Jaroslav Křivánek, MFF UK

Jaroslav.Krivanek@mff.cuni.cz

Kvíz 1

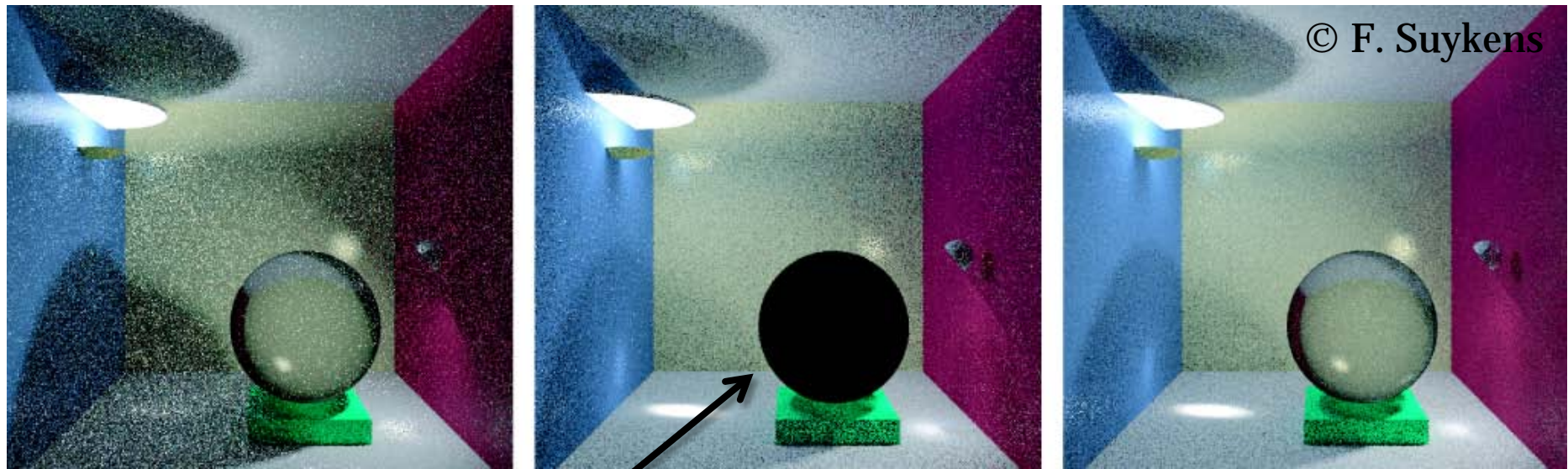

Path tracing

Light tracing

Bidirectional path tracing

Kvíz: Proč je skleněná koule černá?

Kvíz 2

- Proč BPT neumí zobrazit kaustiku na dně bazénu (bodové světlo, pinhole kamera)?
- **„problem of insufficient (sampling) techniques“** [Veach 1997], [Kollig & Keller 2002]
 - Pokud všechny vzorkovací techniky vzorkují daný světelný efekt s malou (nulovou) pravděpodobností, kombinace pomocí MIS na tom nic nezmění.

Fotonové mapy – SDS cesty



© H.W.Jensen



© Wojciech Jarosz

Fotonové mapy – Fáze výpočtu

1. Rozmístění fotonů

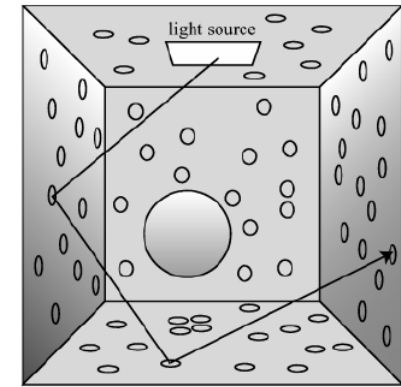

2. Rendering s využitím fotonových map

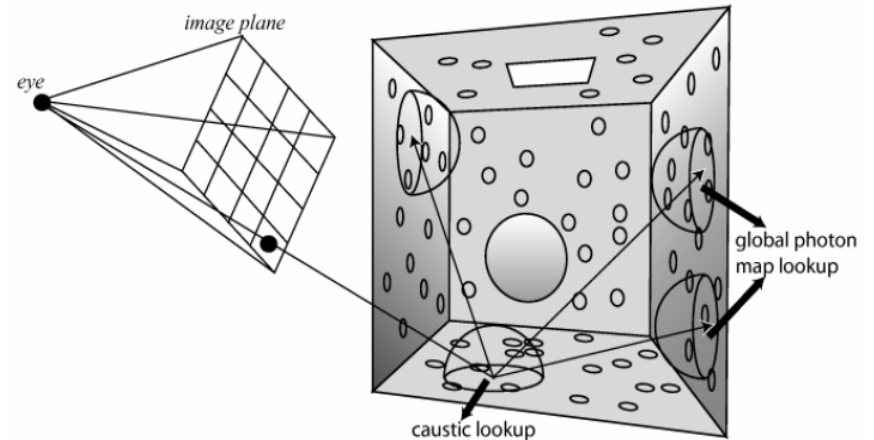

Progresivní fotonové mapy

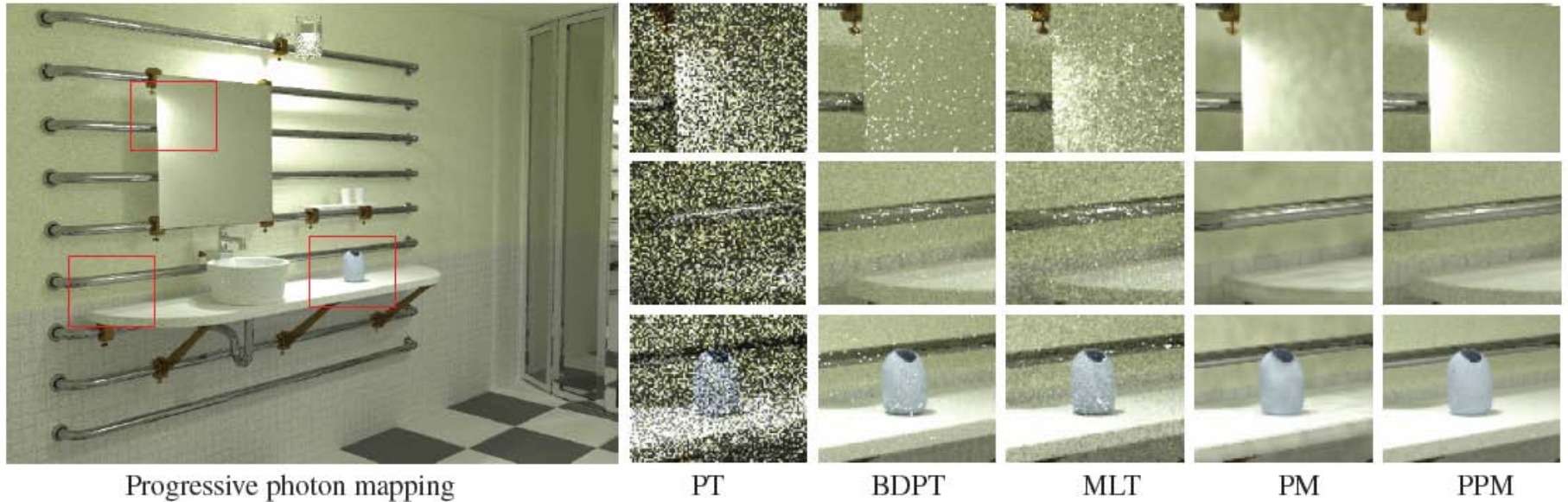
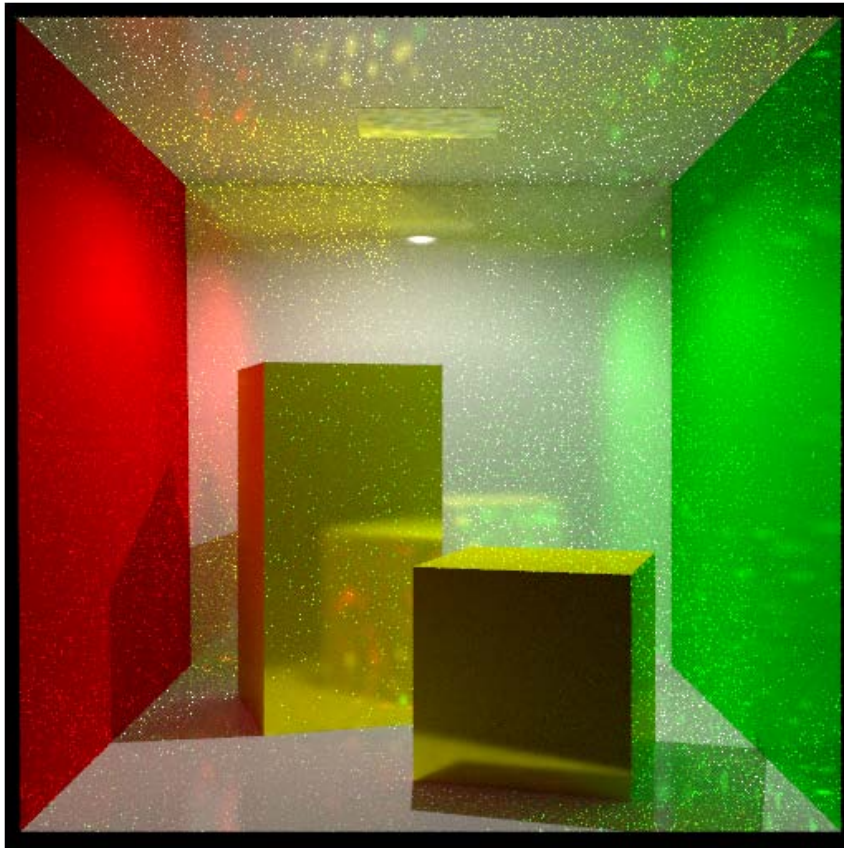
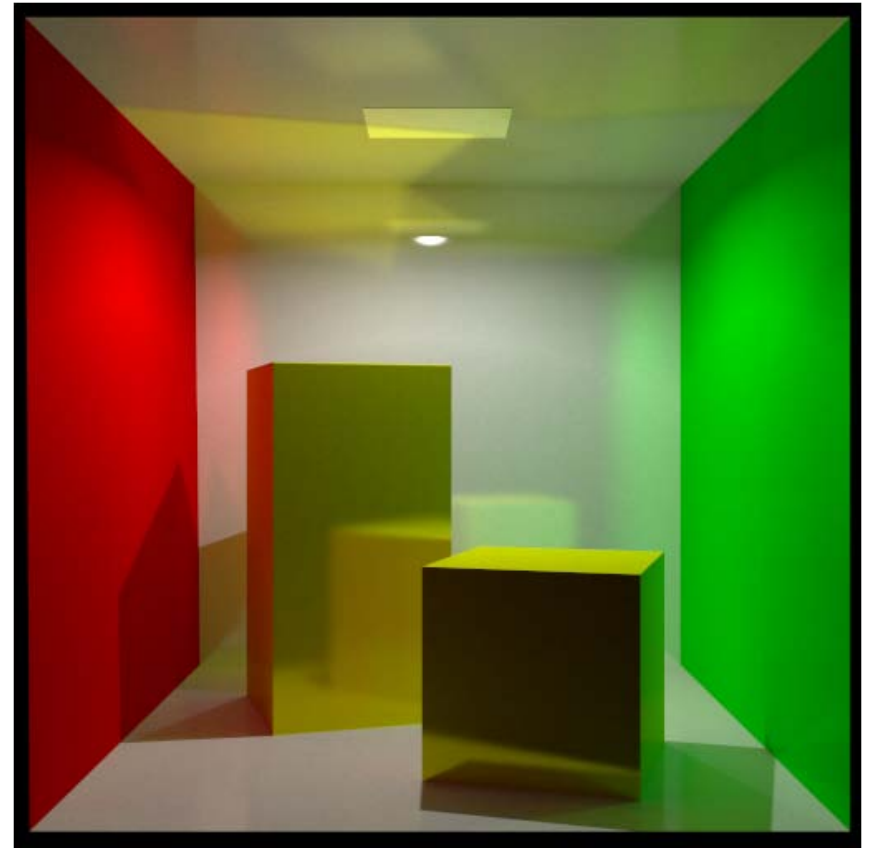

Figure 8: *Lighting simulation in a bathroom. The scene is illuminated by a small lighting fixture consisting of a light source embedded in glass. The illumination in the mirror cannot be resolved using Monte Carlo ray tracing. Photon mapping with 20 million photons results in a noisy and blurry image, while progressive photon mapping is able to resolve the details in the mirror and in the illumination without noise.*

Robustní fotonové mapy



Fotonové mapy
(final gathering)



Naše řešení
(Vorba 2011)

Robustní kombinace BDPT + PPM



Robustní kombinace BDPT + PPM



Robustní kombinace BDPT + PPM



PPM

Robustní kombinace BDPT + PPM



Náš výsledek (Vorba): Robustní PPM

Robustní kombinace BDPT + PPM



Nevyřešené problémy

- **Robustní a efektivní algoritmy pro simulaci transportu světla**
 - Musí fungovat dobře pro scény s různými materiály a světlenými podmínkami
 - Interaktivní odezva (30 fps místo 30 hodin na snímek)

Dnešní přednáška

- **Irradiance caching**
- **Letem světél**
 - teaser na předmět **Vybrané metody GI**

Irradiance & radiance caching

Jaroslav Křivánek

Charles University, Prague

Jaroslav.Krivanek@mff.cuni.cz



Motivation

- **Distribution path tracing (DPT)**

Final gathering

- Estimate illumination integral at a point by tracing many rays (500-5000)
- Costly computation

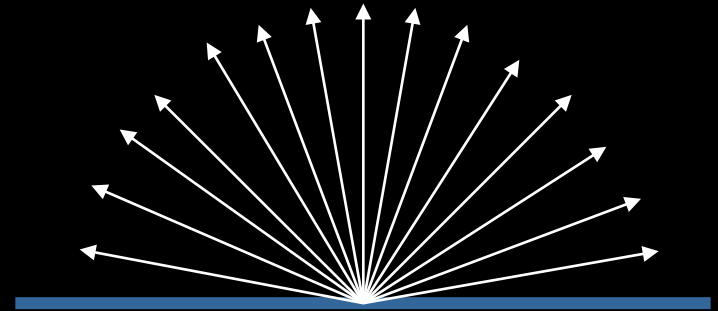

- Irradiance caching accelerates DPT for diffuse indirect illumination

Motivation

- Spatial coherence
 - Diffuse indirect illumination changes slowly over surfaces



Indirect irradiance – changes slowly

Irradiance caching

- Sparse locations for full DRT computation
- Resulting irradiance stored in a cache
- Most pixels interpolated from cached records

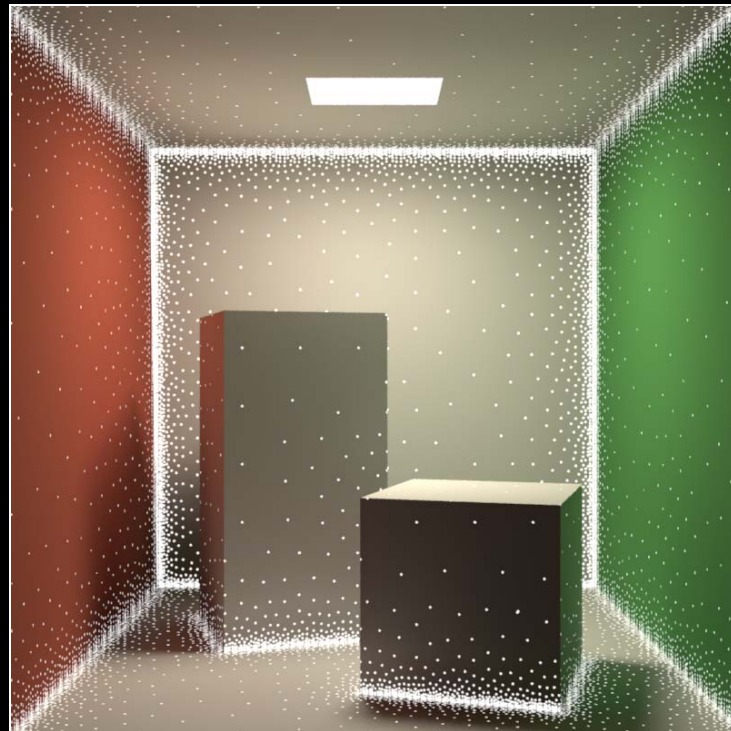
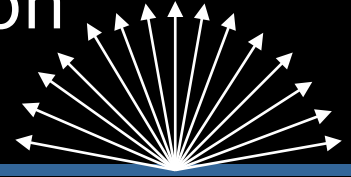

Image credit: Okan Arikan

Irradiance caching

- Faster computation of the *diffuse component* of indirect illumination
- Diffuse reflection

$$L_o(\mathbf{p}) = E(\mathbf{p}) * \rho_d(\mathbf{p}) / \pi$$

- View-independence
 - Outgoing radiance independent of view direction
 - Total irradiance is all we need => cache irradiance

Irradiance caching

- Lazy evaluation of new irradiance values
 - Only if cannot be interpolated from existing ones
- Example: Values E_1 and E_2 already stored
 - Interpolate at A (fast)
 - Extrapolate at B (fast)
 - Add new record at C (slow)

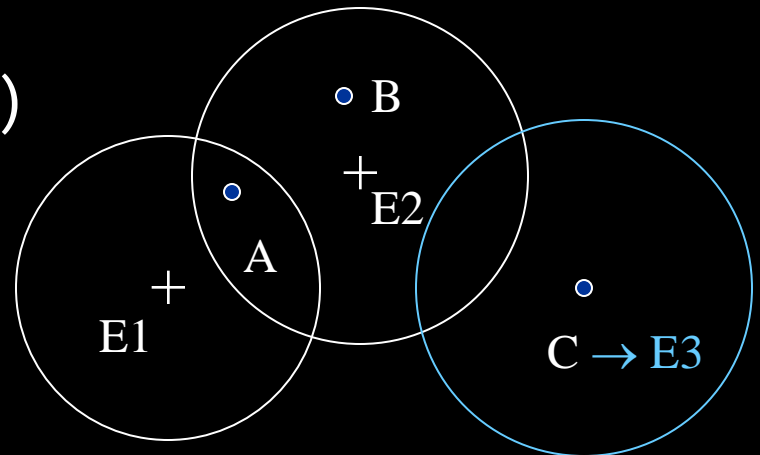

Irradiance caching pseudocode

```
GetIrradiance(p):  
    Color E = InterpolateFromCache(p);  
    if( E == invalid )  
        E = SampleHemisphere(p);  
        InsertIntoCache(E, p);  
    return E;
```

Indirect irradiance calculation

$E = \text{SampleHemisphere}(p);$

- Cast 500-5000 secondary rays (user-specified)
- Compute illumination at intersection
 - Direct illumination only, or
 - Path tracing, or
 - Photon map radiance estimate, or
 - Query in (another) irradiance cache
 - No emission taken into account!

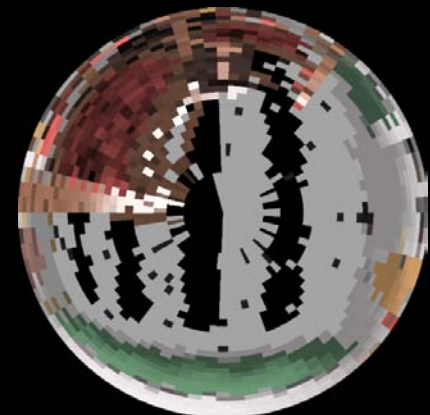
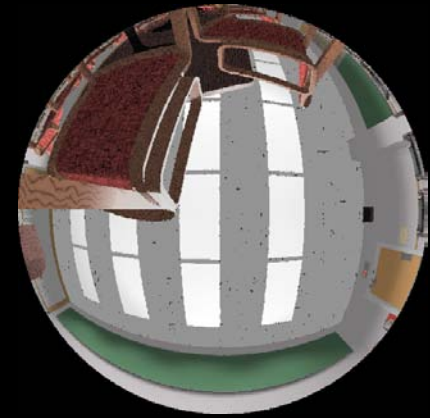
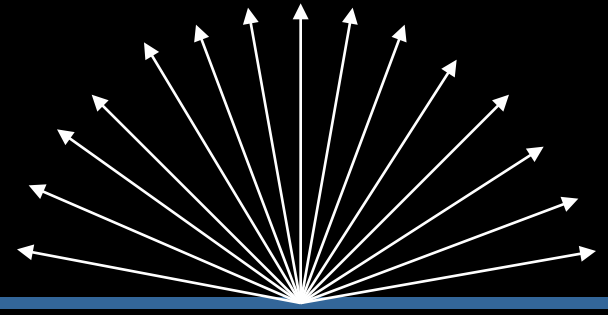

Indirect irradiance calculation

$E = \text{SampleHemisphere}(p);$

- Stratified Monte Carlo hemisphere sampling
 - Subdivide hemisphere into cells
 - Choose a random direction in each cell and trace ray

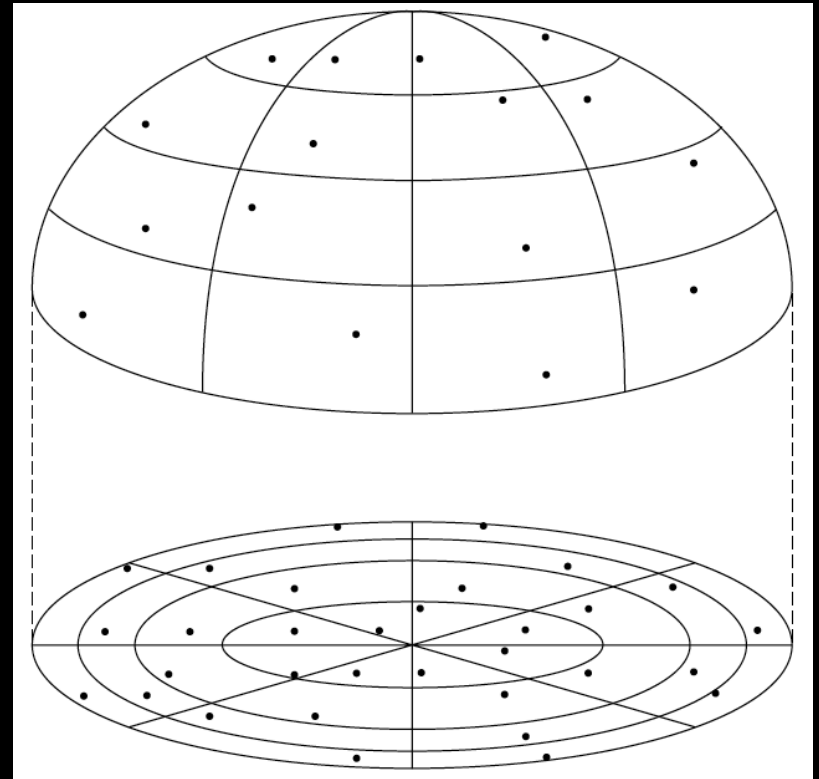

Indirect irradiance calculation

`E = SampleHemisphere(p);`

- Estimating irradiance at \mathbf{p} :

$$E(\mathbf{p}) = \int L_i(\mathbf{p}, \omega_i) \cos \theta_i \, d\omega_i$$

- General form of the estimator

$$E(\mathbf{p}) \approx \frac{1}{MN} \sum_{j=0}^{M-1} \sum_{k=0}^{N-1} \frac{f(\theta_{j,k}, \phi_{j,k})}{p(\theta_{j,k}, \phi_{j,k})}$$

Indirect irradiance calculation

`E = SampleHemisphere(p);`

- For irradiance calculation, the integrand is:

$$L(\theta, \phi) \cos \theta$$

- PDF:

$$p(\theta, \phi) = \frac{\cos \theta}{\pi}$$

Indirect irradiance calculation

- Irradiance estimator for IC:

$$E(\mathbf{p}) \approx \frac{\pi}{MN} \sum_{j=0}^{M-1} \sum_{k=0}^{N-1} L_{j,k}$$

- $L_{j,k}$... radiance sample from direction:

$$(\theta_{j,k}, \phi_{j,k}) = \left(\arccos \sqrt{1 - \frac{j + \zeta_{j,k}^1}{M}}, 2\pi \frac{k + \zeta_{j,k}^2}{N} \right)$$

- M, N ... number of divisions along θ and ϕ
- $\zeta_{j,k}^1, \zeta_{j,k}^2$... random numbers from $R(0,1)$

Irradiance caching pseudocode

GetIrradiance(**p**):

```
Color E = InterpolateFromCache(p);
```

```
if( E == invalid )
```

```
    E = SampleHemisphere(p);
```

```
    InsertIntoCache(E, p);
```

```
return E;
```

Record spacing

- If $E(\mathbf{p})$ changes slowly \Rightarrow interpolate more
- If $E(\mathbf{p})$ changes quickly \Rightarrow interpolate less

- What is the upper bound on rate of change (i.e. gradient) of irradiance?
- Answer from the “worst case” analysis (omitted)

Record spacing

- Near geometry
→ dense spacing
 - Geometry = source of indirect illumination

- Open spaces
→ sparse sampling

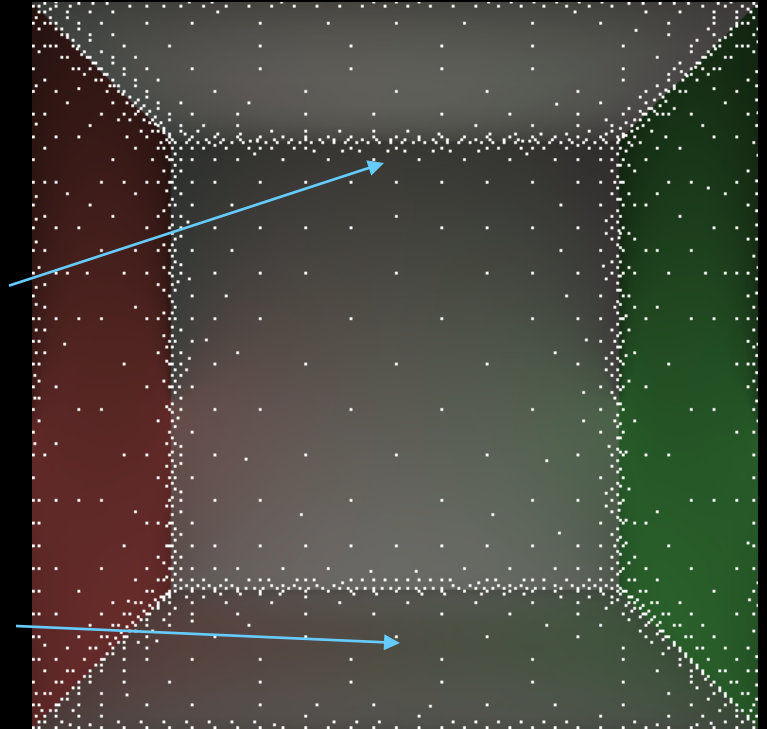

Record spacing



Irradiance interpolation

$E = \text{InterpolateFromCache}(\mathbf{p})$

- Weighted average:
$$E(\mathbf{p}) = \frac{\sum_{i \in S(\mathbf{p})} E_i(\mathbf{p}) w_i(\mathbf{p})}{\sum_{i \in S(\mathbf{p})} w_i(\mathbf{p})},$$

- Records used for interpolation:

$$S(\mathbf{p}) = \{i; w_i(\mathbf{p}) > 0\}$$

Weighting function

[Tablellion and Lamorlette 04]

$$w_i(\mathbf{p}) = 1 - \kappa \max \left\{ \frac{\|\mathbf{p} - \mathbf{p}_i\|}{\text{clamp}(2R_i, R_{\min}, R_{\max})}, \frac{\sqrt{1 - \mathbf{n} \cdot \mathbf{n}_i}}{\sqrt{1 - \cos 10^\circ}} \right\}$$

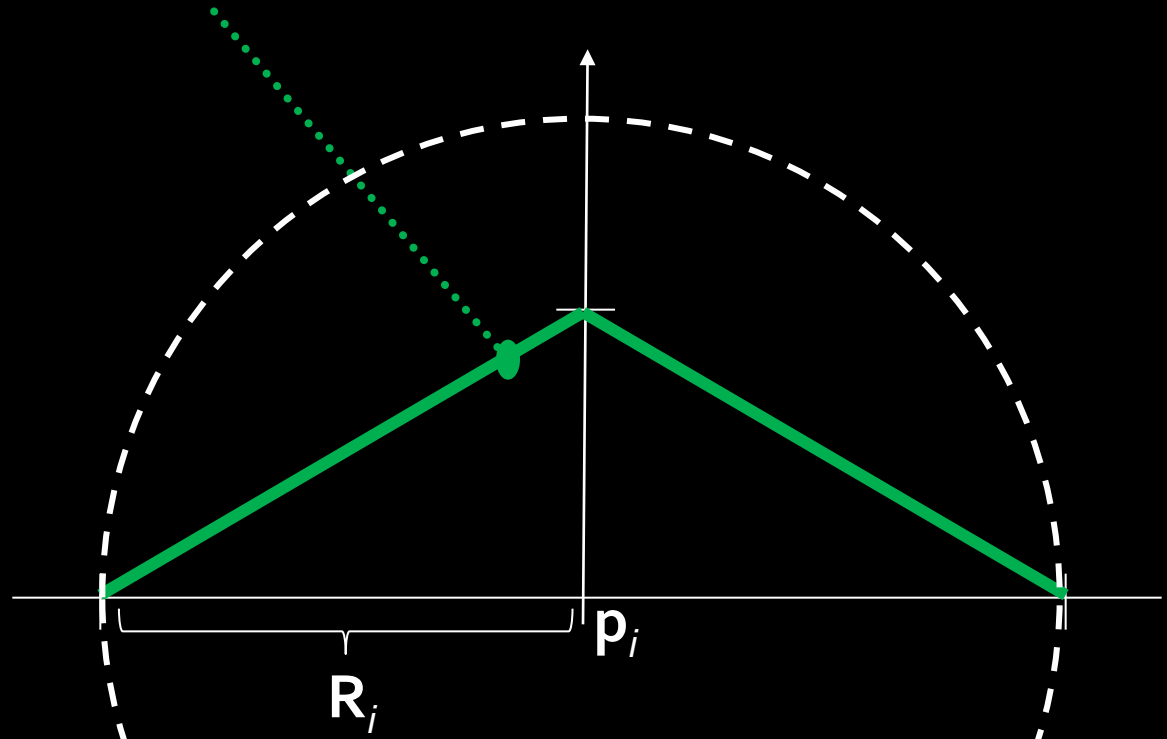

Heuristic “behind” test

- Record at \mathbf{p}_i rejected from interpolation at \mathbf{p} if \mathbf{p} is “behind” \mathbf{p}_i

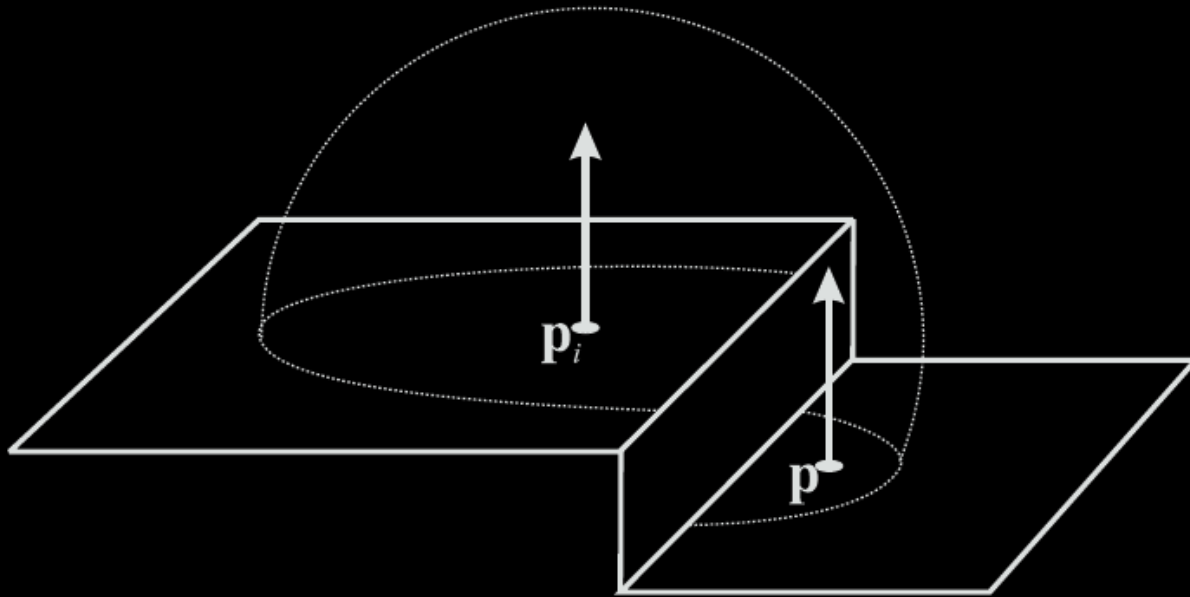

Irradiance caching pseudocode

GetIrradiance(**p**):

```
Color E = InterpolateFromCache(p);
```

```
if( E == invalid )
```

```
    E = SampleHemisphere(p);
```

```
    InsertIntoCache(E, p);
```

```
return E;
```

Irradiance cache record

`InsertIntoCache(E, p);`

- `Vector3 position` Position in space
- `Vector3 normal` Normal at 'position'
- `float R` Validity radius
- `Color E` Stored irradiance
- `Color dEdP[3]` Gradient w.r.t. translation
- `Color dEdN[3]` Gradient w.r.t. rotation

Irradiance cache data structure

`InsertIntoCache(E, p);`

- Requirements
 - Fast incremental updates
(records stored on the fly)
 - Fast query for all records (spheres) overlapping a given point p

Data structure: Octree

`InsertIntoCache(E, p);`

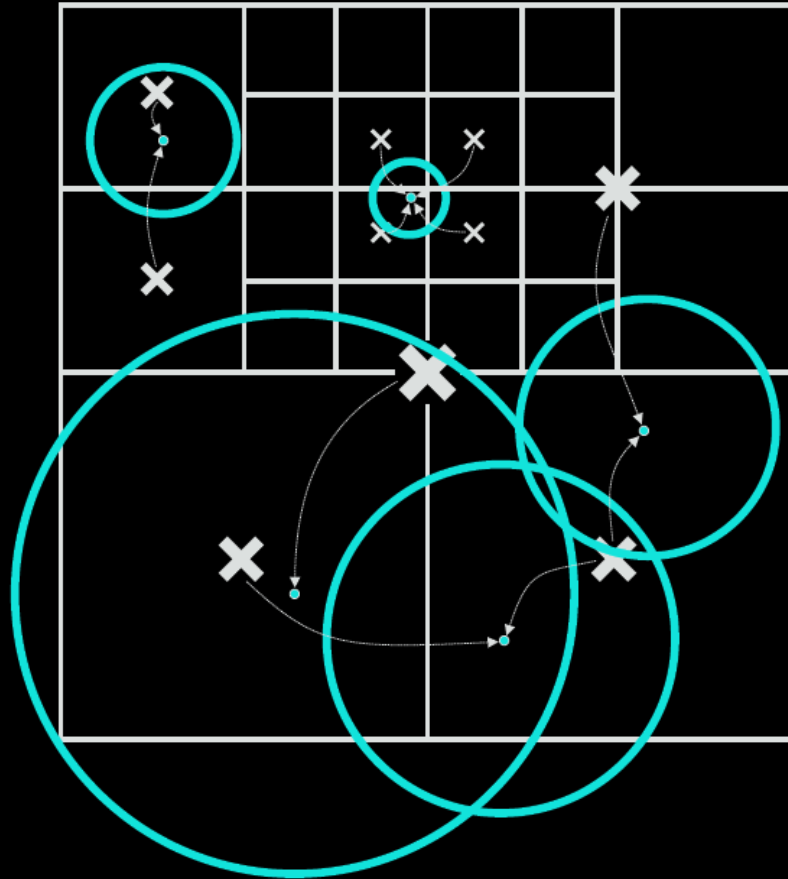

Data structure: Octree

back to ... $\mathbf{E} = \text{InterpolateFromCache}(\mathbf{p})$

procedure LookUpRecordsMR(\mathbf{p}, \mathbf{n})

node \leftarrow root

while node \neq NULL **do**

for all records i stored in node **do**

if ($w_i(\mathbf{p}) > 0$) **and** (\mathbf{p}_i not in front of \mathbf{p}) **then**

 Include record in $S(\mathbf{p})$.

end if

end for

 node \leftarrow child containing \mathbf{p}

end while

end procedure

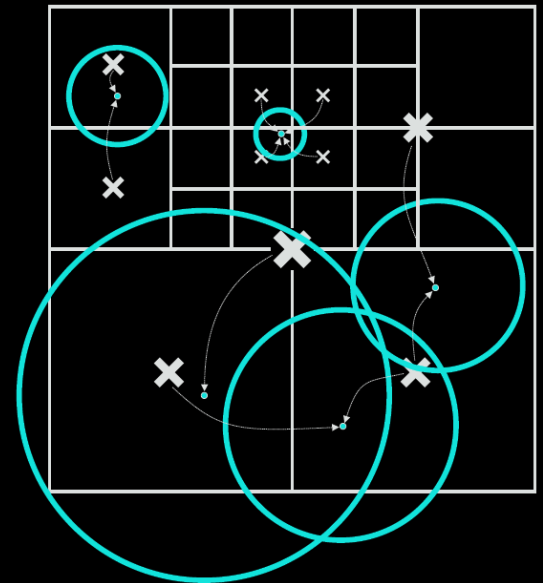

Irradiance gradients

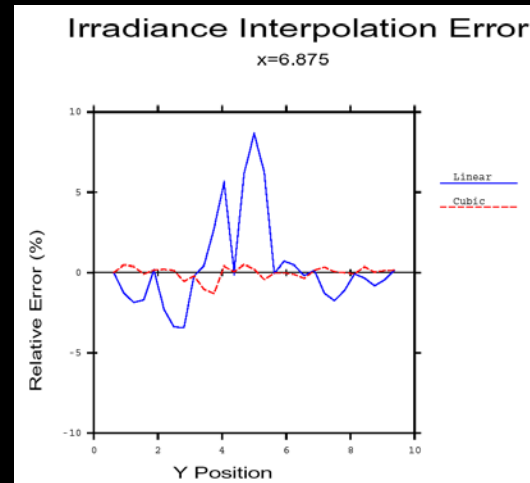
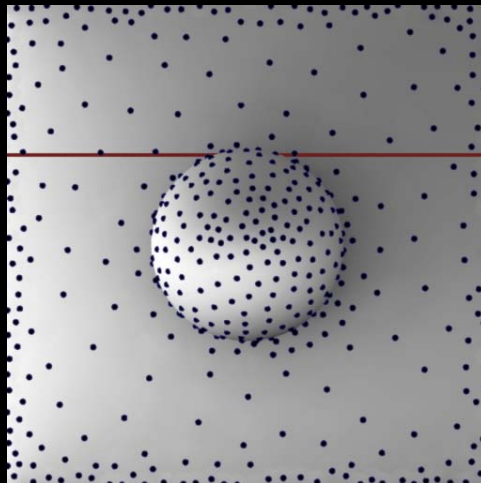
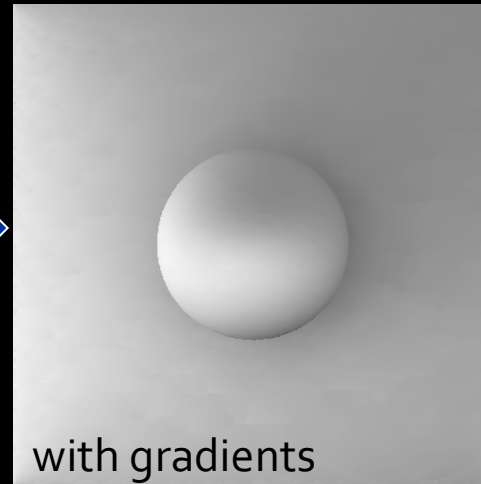

Irradiance gradients

- Essential for smooth interpolation
- Calculated during hemisphere sampling
 - i.e. no extra rays, little overhead
- Stored as a part of the record in the cache
- Used in interpolation

Rotation gradient

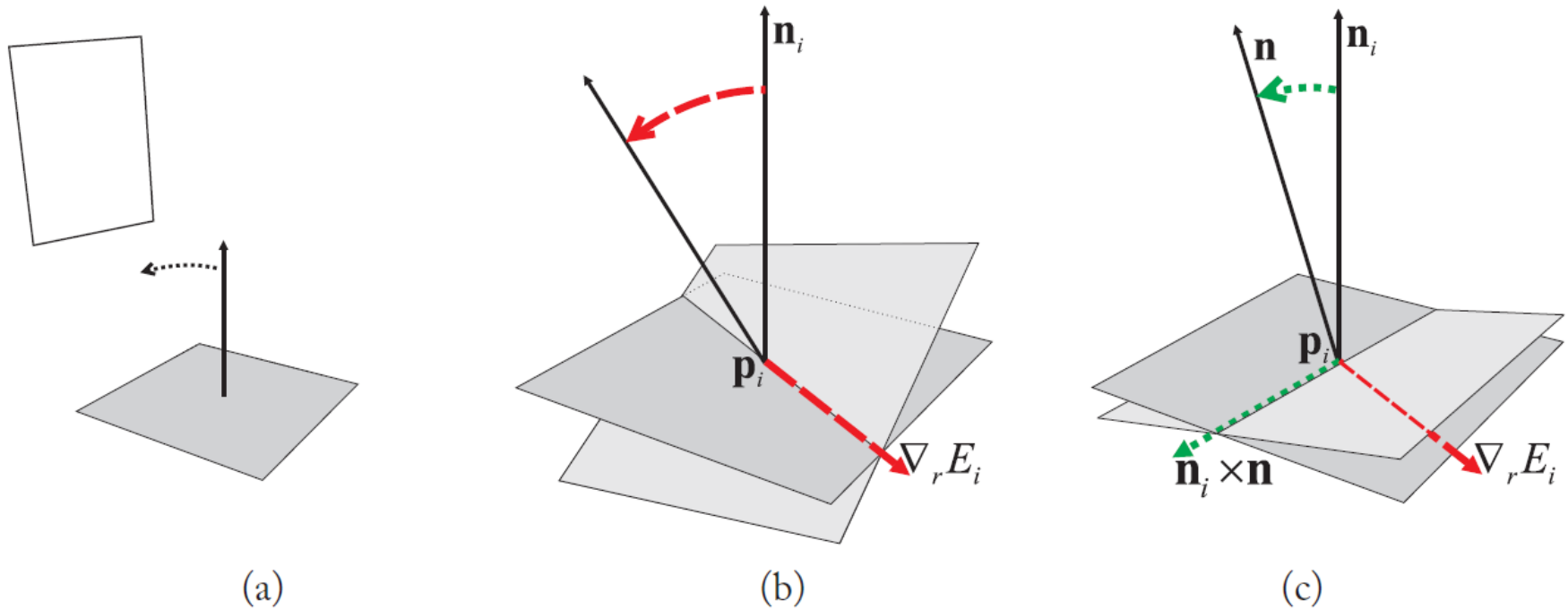
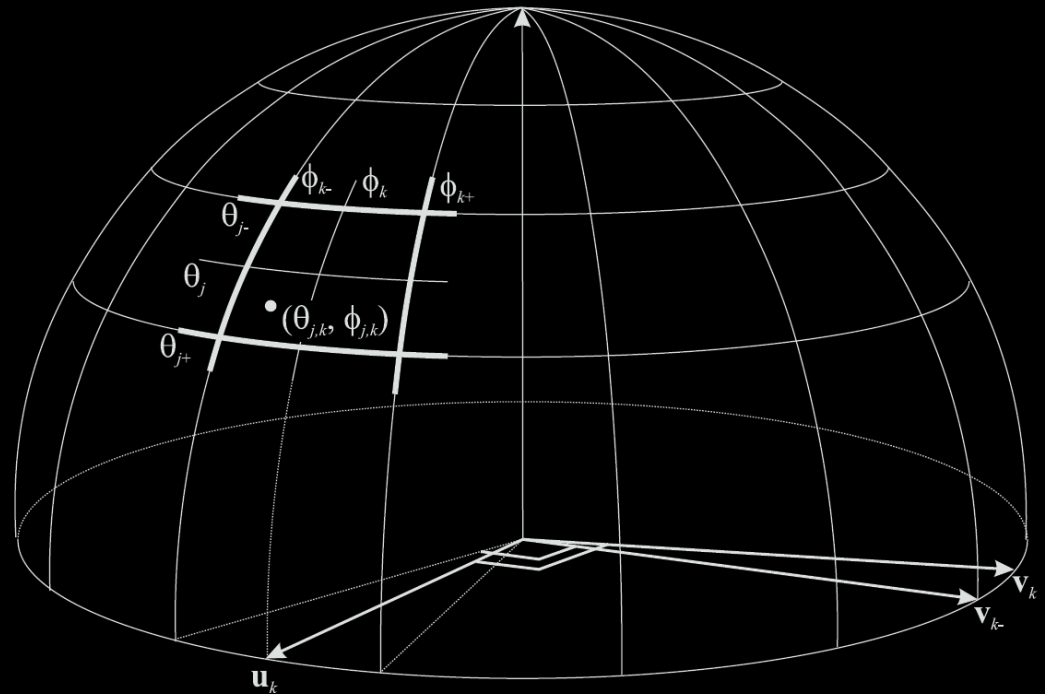

Figure 2.4: (a) As the surface element is rotated towards the bright surface, irradiance increases. (b) The rotation gradient $\nabla_r E_i$ of cache record i gives the axis of rotation that produces maximum increase in irradiance. The gradient magnitude is the irradiance derivative with rotation around that axis. (c) When the surface element is rotated around any arbitrary axis (in our example determined by the change in surface normal as $\mathbf{n}_i \times \mathbf{n}$) the irradiance derivative is given by the dot product of the axis of rotation and the rotation gradient: $(\mathbf{n}_i \times \mathbf{n}) \cdot \nabla_r E_i$.

Rotation gradient formula

$$\nabla_r E \approx \frac{\pi}{MN} \sum_{k=0}^{N-1} \left(\mathbf{v}_k \sum_{j=0}^{M-1} -\tan \theta_j \cdot L_{j,k} \right)$$



Translation gradient

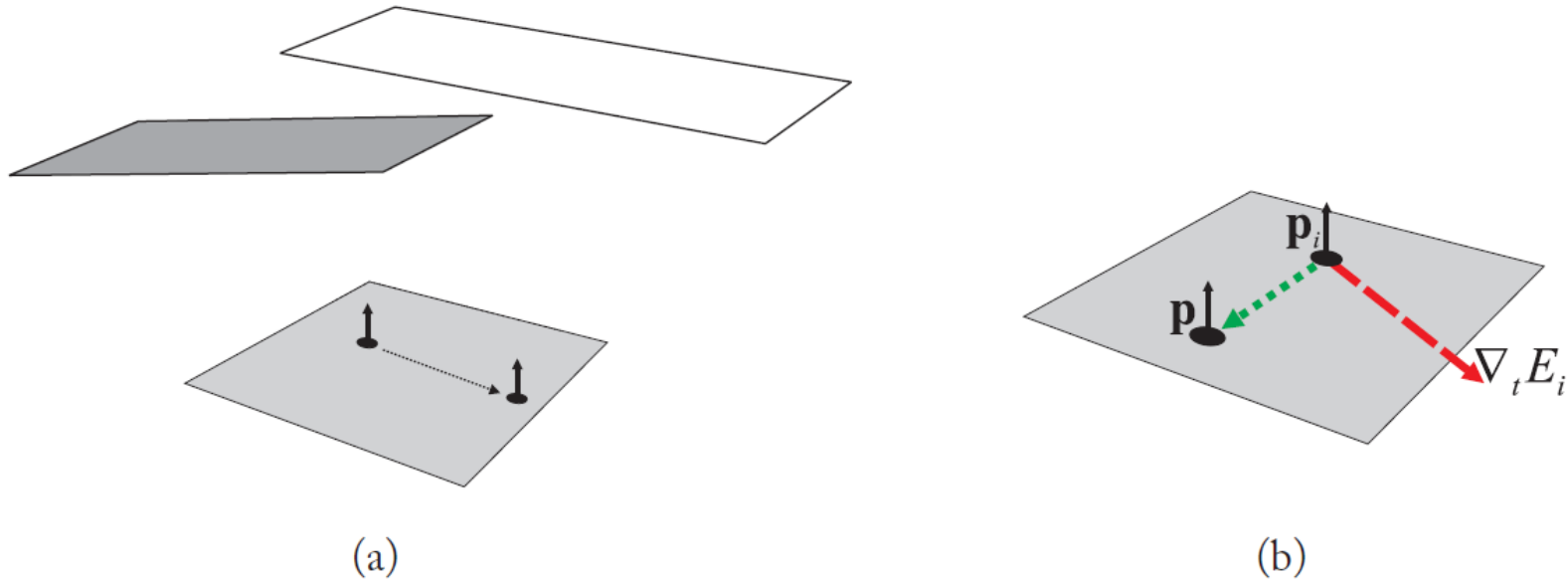
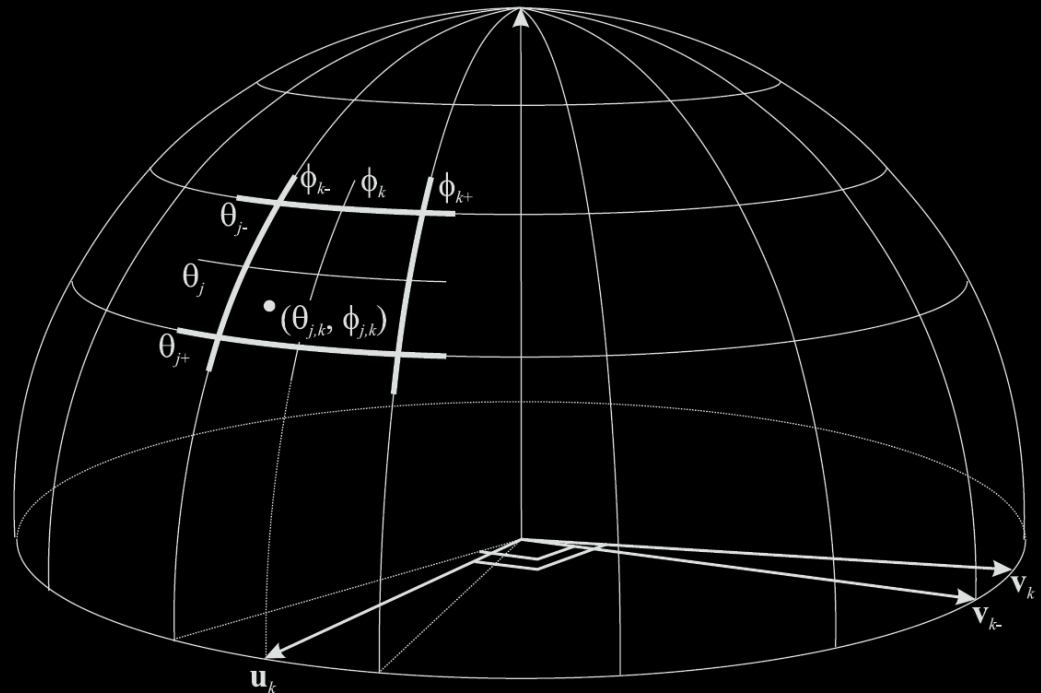

Figure 2.6: (a) As the surface element is translated, it becomes more exposed to the bright surface, and irradiance increases. (b) The translation gradient $\nabla_t E_i$ of record i gives the direction of translation that produces the maximum increase in irradiance. The gradient magnitude is the irradiance derivative with respect to translation along that direction. When a surface element is translated along any arbitrary direction, a first-order approximation of the change in irradiance is given by the dot product of the translation vector and the translation gradient: $(\mathbf{p} - \mathbf{p}_i) \cdot \nabla_t E_i$.

Translation gradient formula

$$\nabla_t E \approx \sum_{k=0}^{N-1} \left[\mathbf{u}_k \frac{2\pi}{N} \sum_{j=1}^{M-1} \frac{\cos^2 \theta_{j-} \sin \theta_{j-}}{\min\{r_{j,k}, r_{j-1,k}\}} (L_{j,k} - L_{j-1,k}) + \mathbf{v}_{k-} \sum_{j=0}^{M-1} \frac{\cos \theta_j (\cos \theta_{j-} - \cos \theta_{j+})}{\sin \theta_{j,k} \min\{r_{j,k}, r_{j,k-1}\}} (L_{j,k} - L_{j,k-1}) \right]$$



Irradiance interpolation w/ grads

$E = \text{InterpolateFromCache}(\mathbf{p})$

- Weighted average:
$$E(\mathbf{p}) = \frac{\sum_{i \in S(\mathbf{p})} E_i(\mathbf{p}) w_i(\mathbf{p})}{\sum_{i \in S(\mathbf{p})} w_i(\mathbf{p})},$$

$$E_i(\mathbf{p}) = E_i + (\mathbf{n}_i \times \mathbf{n}) \cdot \nabla_r E_i + (\mathbf{p} - \mathbf{p}_i) \cdot \nabla_t E_i$$

Irradiance caching examples

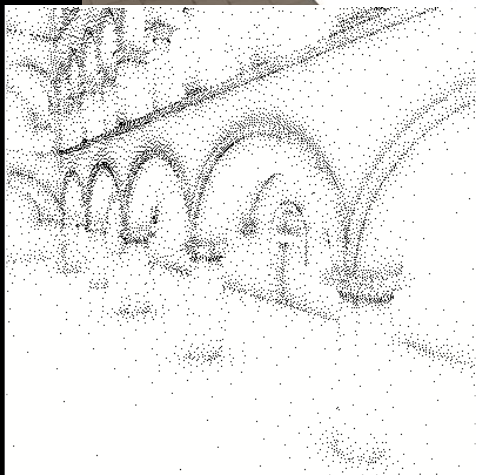
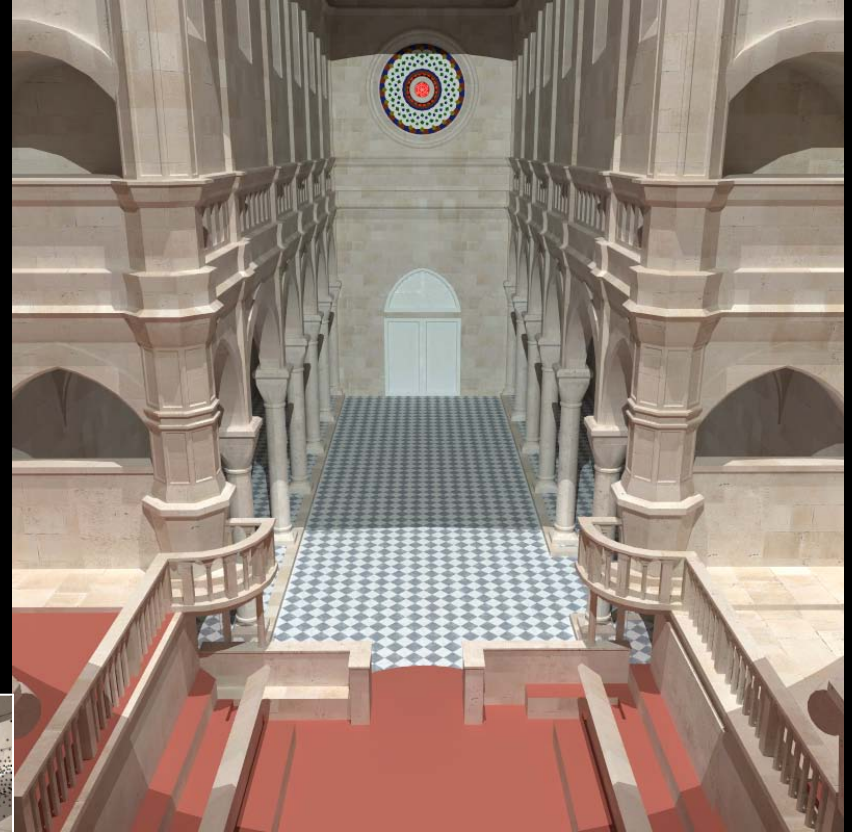

Irradiance caching examples



Irradiance caching examples



Ambient occlusion

$$A(\mathbf{p}) = \frac{1}{\pi} \int_{H^+} V(\mathbf{p}, \omega) \cos \theta \, d\omega$$

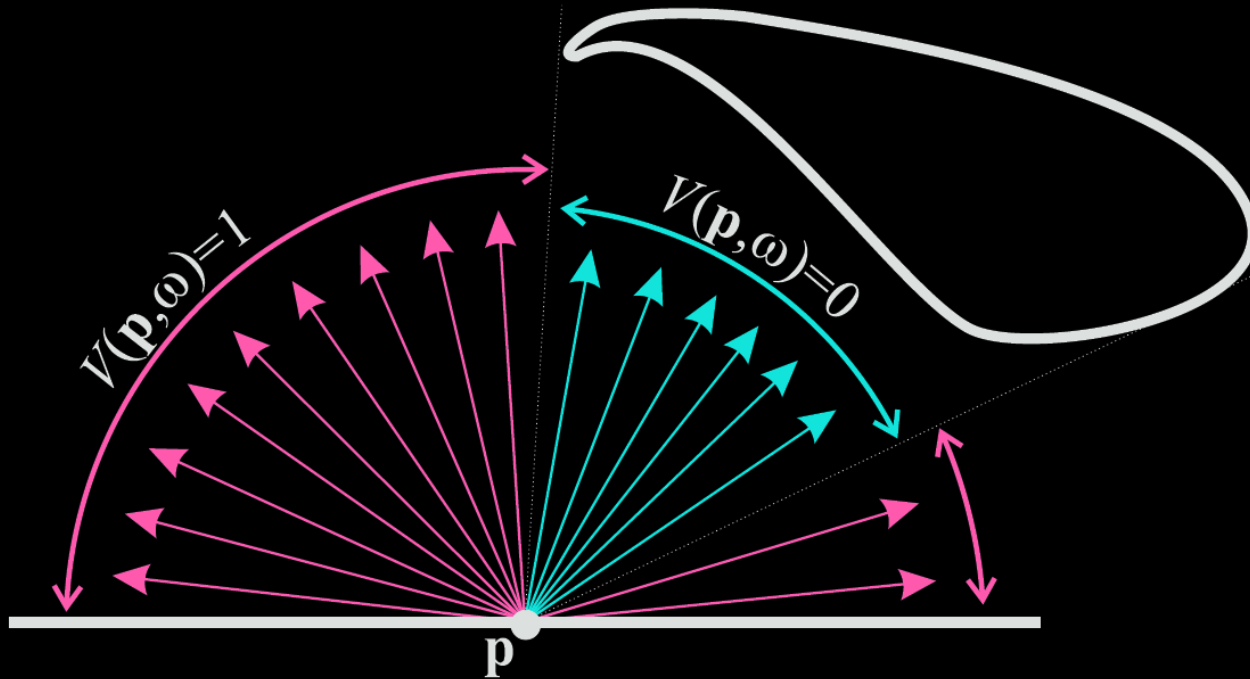

Ambient occlusion



X



=



Ambient occlusion caching

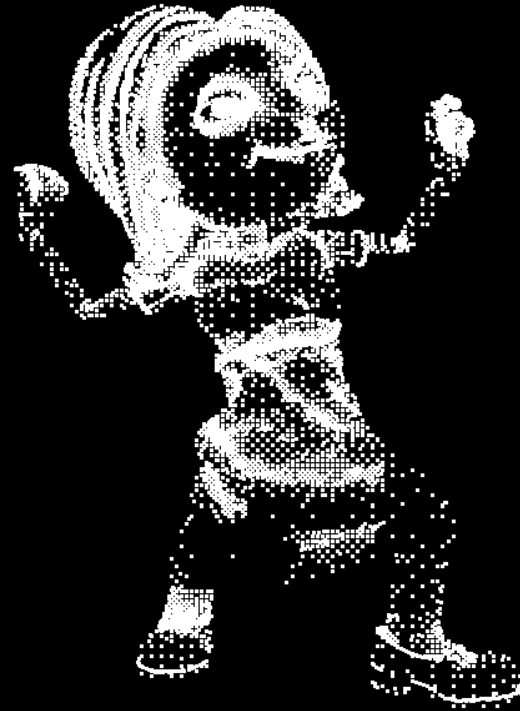

Conclusion

- Fast indirect illumination of diffuse surfaces
 - Sparse sampling & fast interpolation
- Consistent but not unbiased
- Tons of implementation details that I did not discuss here

Irradiance caching history

- 1988: Ward et al.
 - Original idea
- 1992: Ward and Heckbert
 - Irradiance Gradients
- 1996: Jensen
 - IC part of Photon maps
- 2004: Tabellion and Lamorlette
 - First use of GI in film (Shrek2)
- 2005: Krivanek et al.
 - Extension to glossy surfaces
- 2008: Jarosz et al.
 - Caching for Participating media
- ... lots of other work

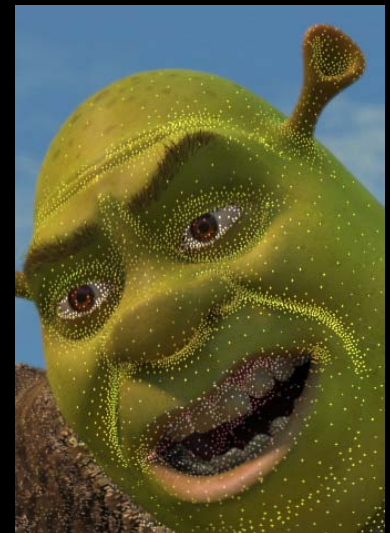
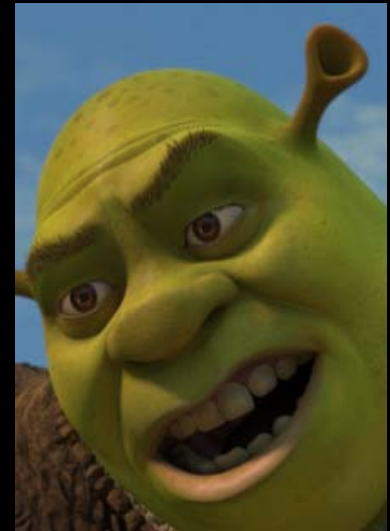

Further reading

- Practical Global Illumination with Irradiance Caching
 - SIGGRAPH Course: 2008, Křivánek et al.
 - Book, 2009, Křivánek & Gautron
 - Both give references to further resources

Letem světem...

Letem světem

- Teaser na předmět **Vybrané metody GI**
 - Metropolis Light Transport
 - Virtuální světla + škálovatelné metody
 - Předpočítaný přenos radiance
 - Opticky aktivní média + subsurface scattering
 - Real-Time GI
 - Zobrazování vlasů
 - Modelování vzhledu

Metropolis Light Transport

- Aplikace vzorkovací metody **Metropolis-Hastings** na vzorkování funkce příspěvku světelné cesty
 - **Mutace cest**
- [Veach 1997]



(a) Bidirectional path tracing with 40 samples per pixel.



(b) Metropolis light transport with an average of 250 mutations per pixel [the same computation time as (a)].

Image credit: Eric Veach

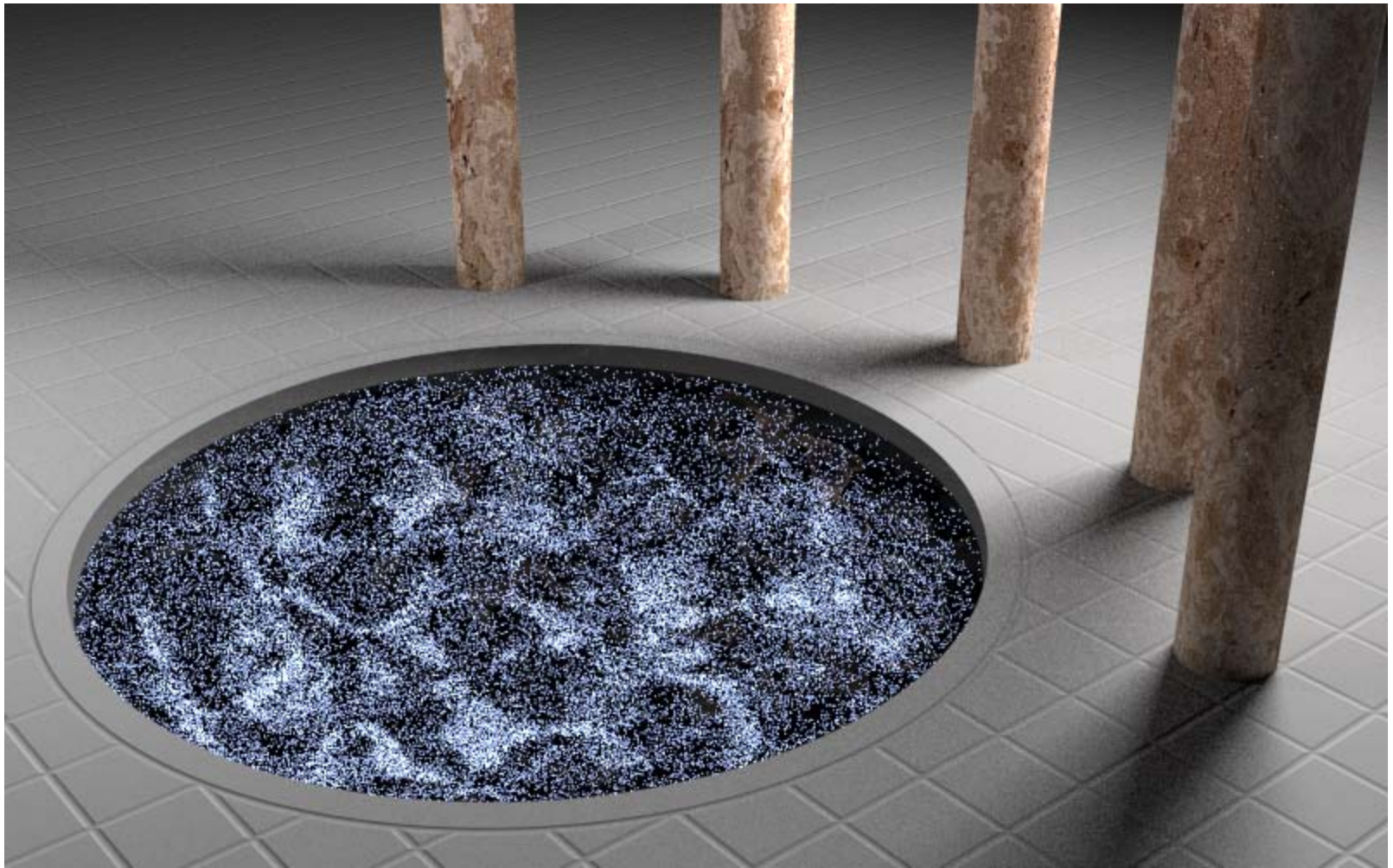

(a) Path tracing with 210 samples per pixel.

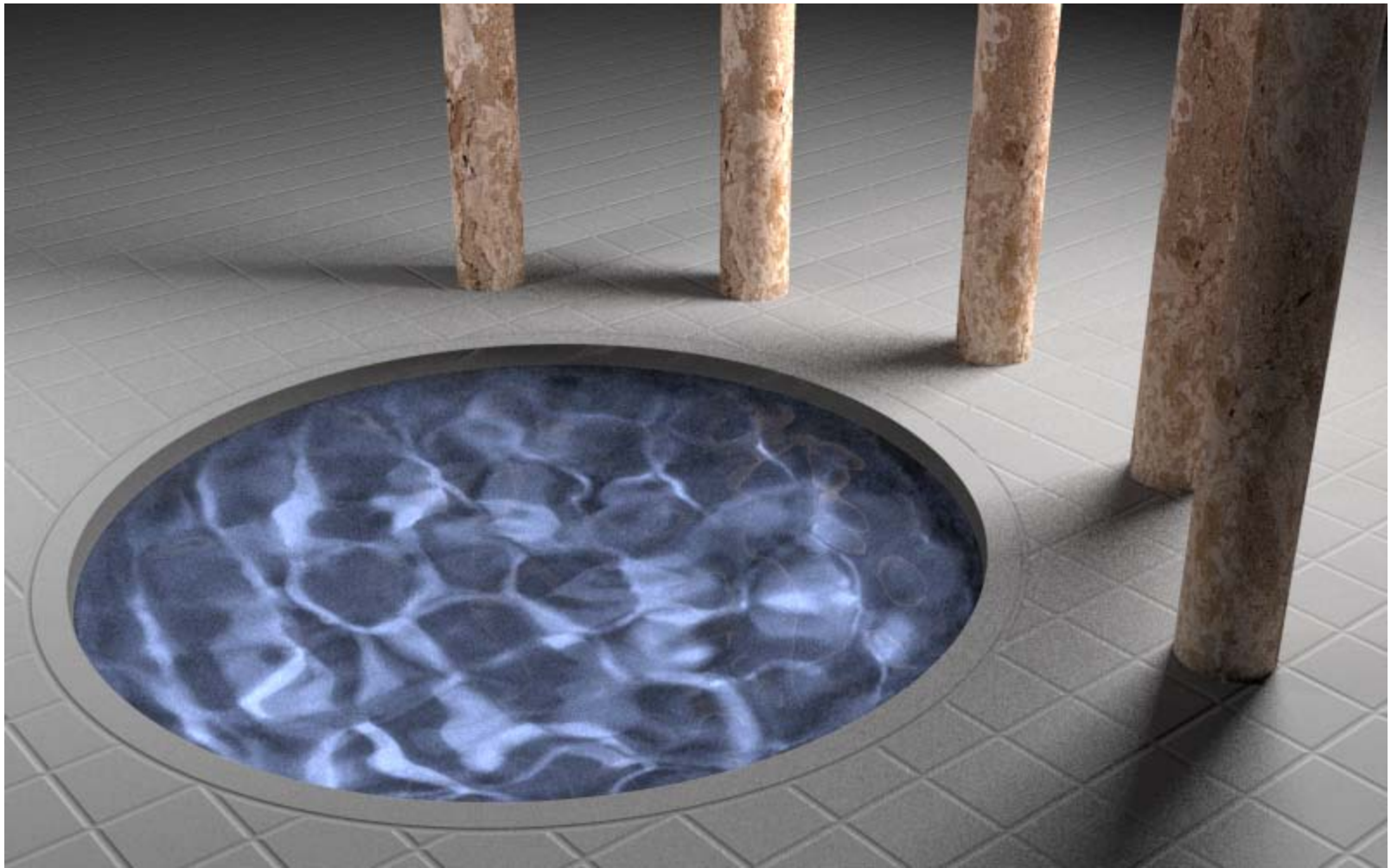

(b) Metropolis light transport with an average of 100 mutations per pixel [the same computation time as (a)].

Image credit: Eric Veach

Metropolis Photon Tracing

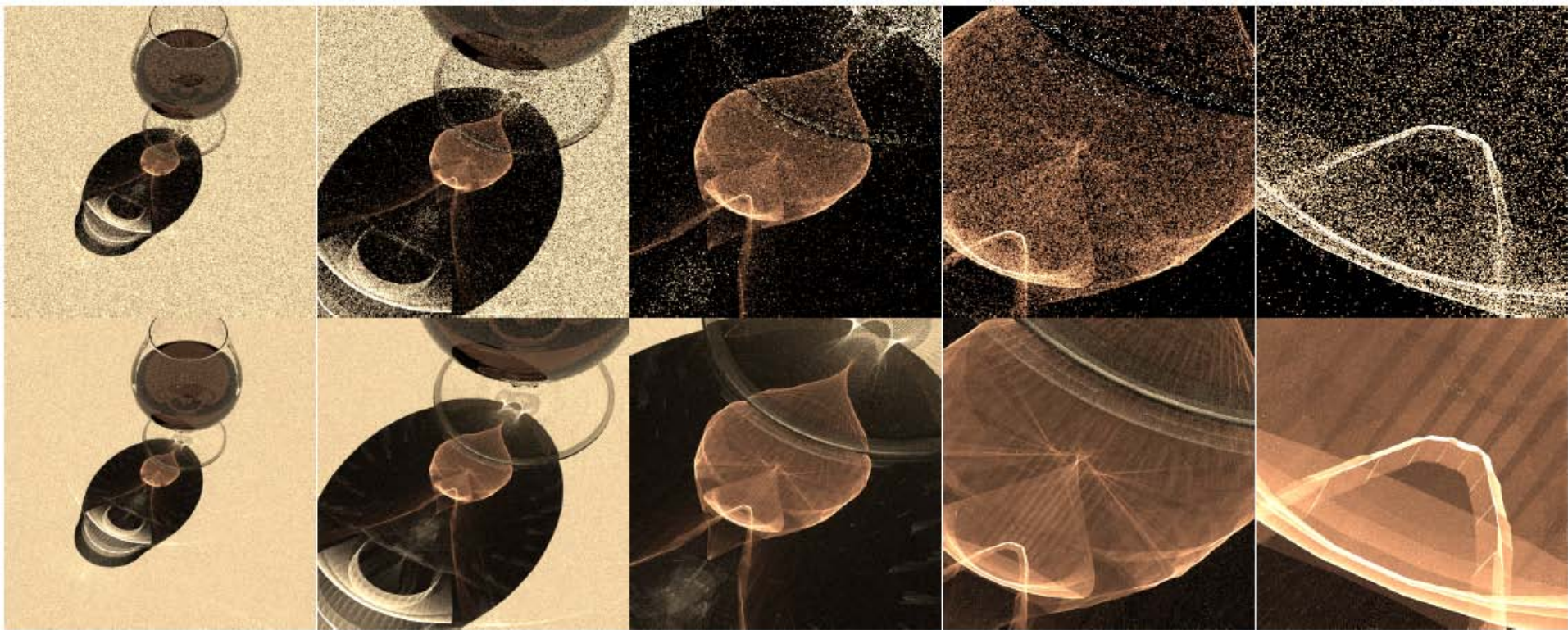

Image credit: Toshiya Hachisuka

Instant radiosity (VPL rendering)

- [Keller 1997]
- Approximate indirect illumination by

Virtual Point Lights (VPLs)

1. Generate VPLs

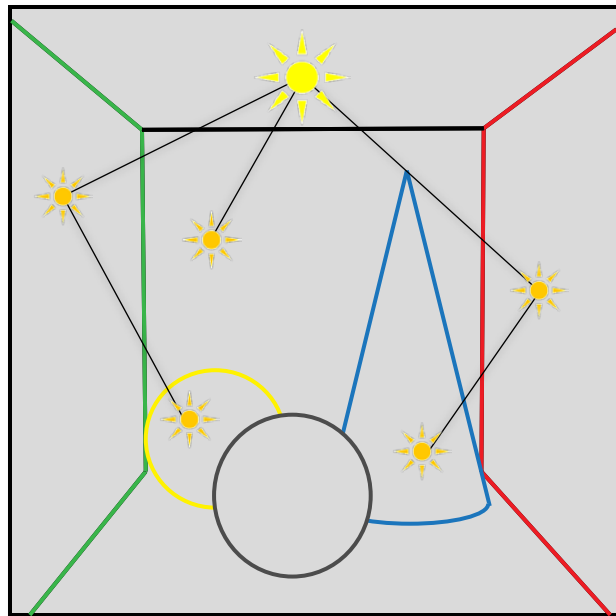

2. Render with VPLs

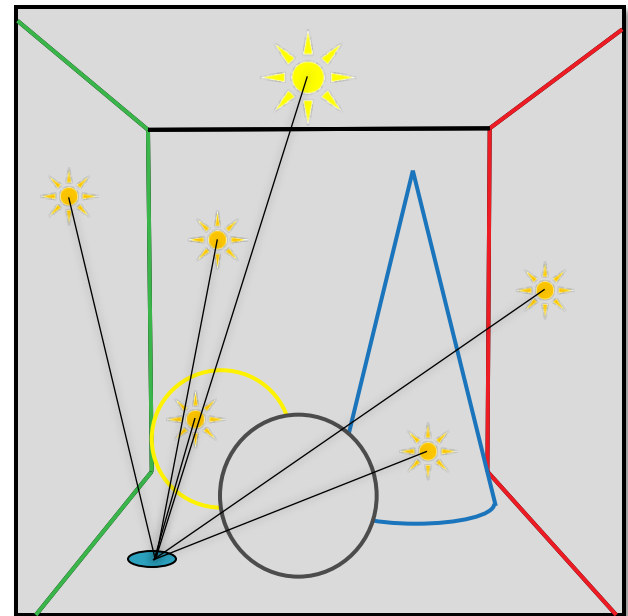

Škálovatelné VPL metody

- **Škálovatelné VPL metody**
 - Lightcuts [Walter et al. 2006]
 - Matrix Row-Column Sampling [Hašan et al. 2007]
 - LightSlice [Ou et al. 2011]
- **Robustní VPL metody (naše práce)**
 - Virtual spherical Lights [Hašan et al. 2009]
 - Local lights [Davidovič et al. 2010]

Předpočítaný přenos radiance

$$\begin{bmatrix} P_1 \\ P_2 \\ P_3 \\ \vdots \\ P_N \end{bmatrix}$$



$$= \begin{bmatrix} T_{11} & T_{12} & \cdots & T_{1M} \\ T_{21} & T_{22} & \cdots & T_{2M} \\ T_{31} & T_{32} & \cdots & T_{3M} \\ \vdots & \vdots & \ddots & \vdots \\ T_{N1} & T_{N2} & \cdots & T_{NM} \end{bmatrix} \begin{bmatrix} L_1 \\ L_2 \\ \vdots \\ L_M \end{bmatrix}$$



Opticky aktivní média



Subsurface scattering examples



Real

Simulated

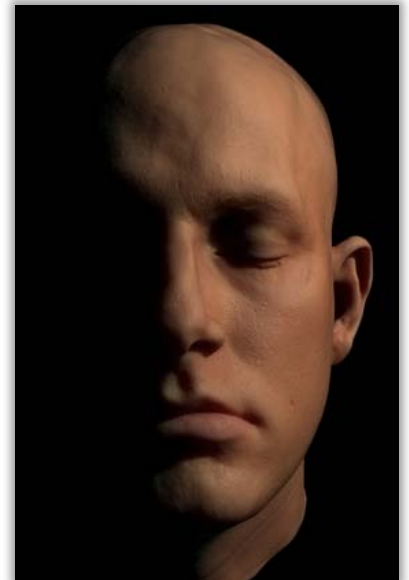

Real-time GI

- **Techniky založené na VPL**
- **Screen-space techniky**
- **Implicitní viditelnost & anti-radiance**

Zobrazování vlasů



Single Scattering Only
(offline)
3 minutes

Path Tracing Reference
(offline)
22 hours

Modelování vzhledu

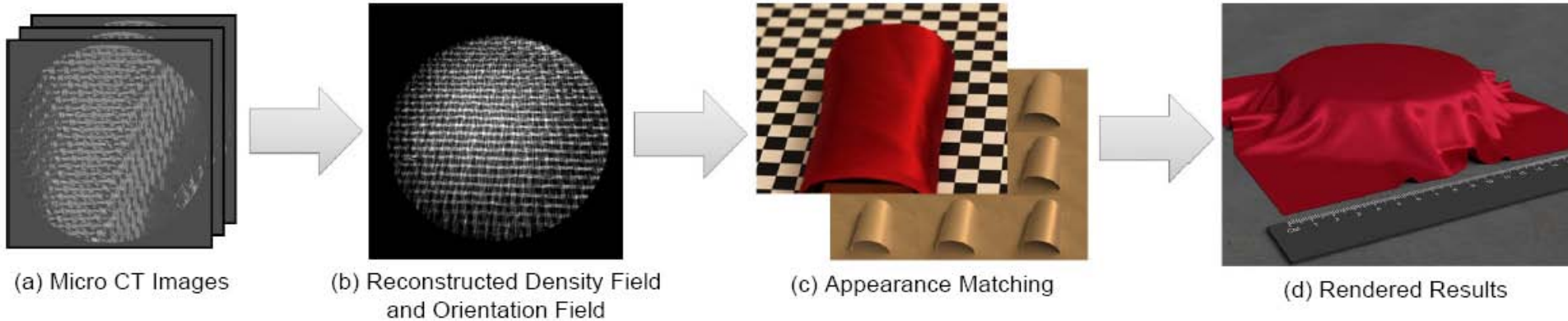

Závěr

Research challenges in rendering

- Existing algorithms are inherently bad for some practical scenes



- More work to do for rendering researchers

What else in CG

- Main general CG conferences
 - SIGGRAPH (ACM Transactions on Graphics – TOG)
 - SIGGRAPH Asia (ACM TOG)
 - Eurographics (Computer Graphics Forum)
- <http://kesen.realtimerendering.com/>

What else in CG

- Computational photography
- Appearance modeling & capture
- Animation (& capture)
- Dynamic simulation (hair, cloth, water, smoke, solids...)
- Visual perception
- Natural phenomena
- Non-photorealistic rendering
- Sound simulation
- Display technology
- Interaction technology
- Geometry modeling

General challenges in CG

- **Making CG usable (!!!)**
- **Robust and efficient** lighting simulation in general scenes
- Virtual human
 - **Hair modeling (!!!)**
 - **Animation (!!!)**
 - Cloth
- Managing complexity
 - Natural environments etc
- Virtual Worlds (shared 3D graphics)
- ...and more (the above is my random choice of “grand challenges”)