

# N P R

Non-Photorealistic Rendering & Animation

Frantisek Psozka

# PR vs. NPR

- PR - čo najvernejšie zobrazenie „reality“
- NPR - čo najefektívnejší prenos informácie
  - „normálny prístup“ - komunikácia obrazom
  - účelnosť a zrozumiteľnosť (slovný test)
  - abstrakcia od zobrazovanej reality
  - umenie, resp. simulácia umenia (Turingov test)
  - výskum interpretácie grafického vyjadrenia

# Použitie NPR

- Mapy, technická dokumentácia, CAD
- náčrty (v manuáloch ...), piktogramy, web
- Vizualizácia (medicína, meteorológia...)
- Umenie:
  - automatická kresba, maľba
  - Toon rendering (Tom a Jerry...)
  - rytiny, litografie, drevotlač
  - film (Lord of the Rings, Naqoyqatsi,...)
  - interaktívne umenie (Painkiller,...)

# Pen & Ink

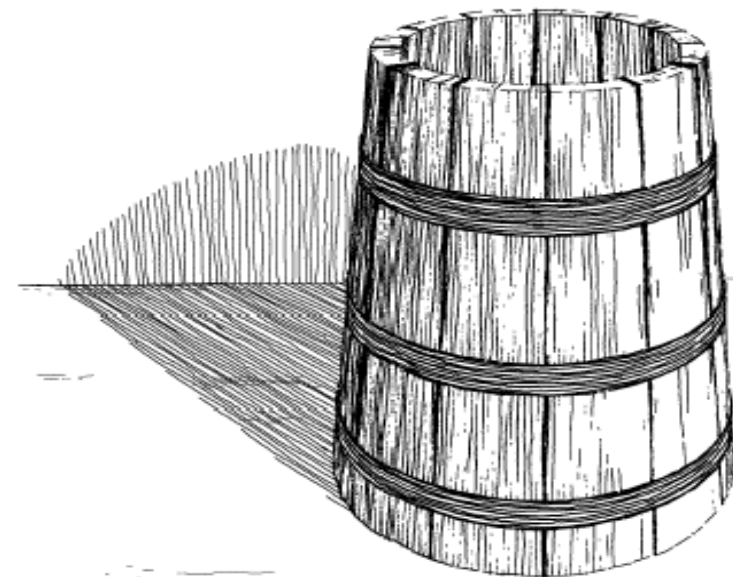
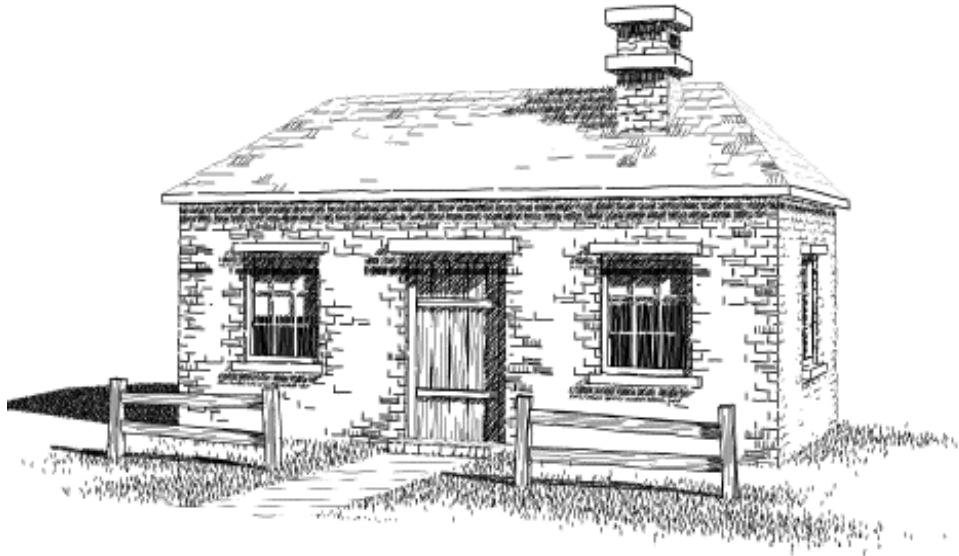

# Engraving

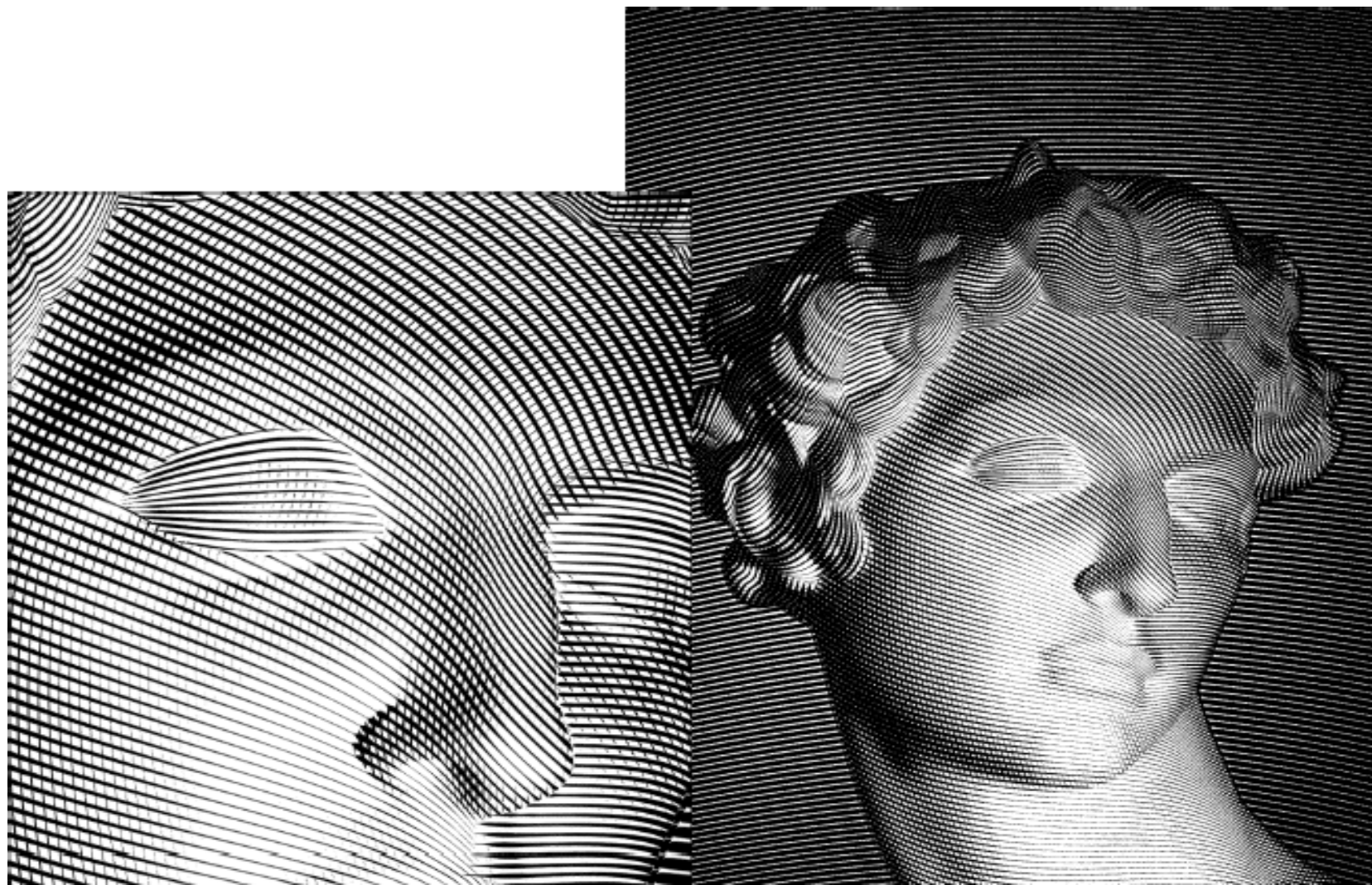

# Painterly Rendering





# CAD

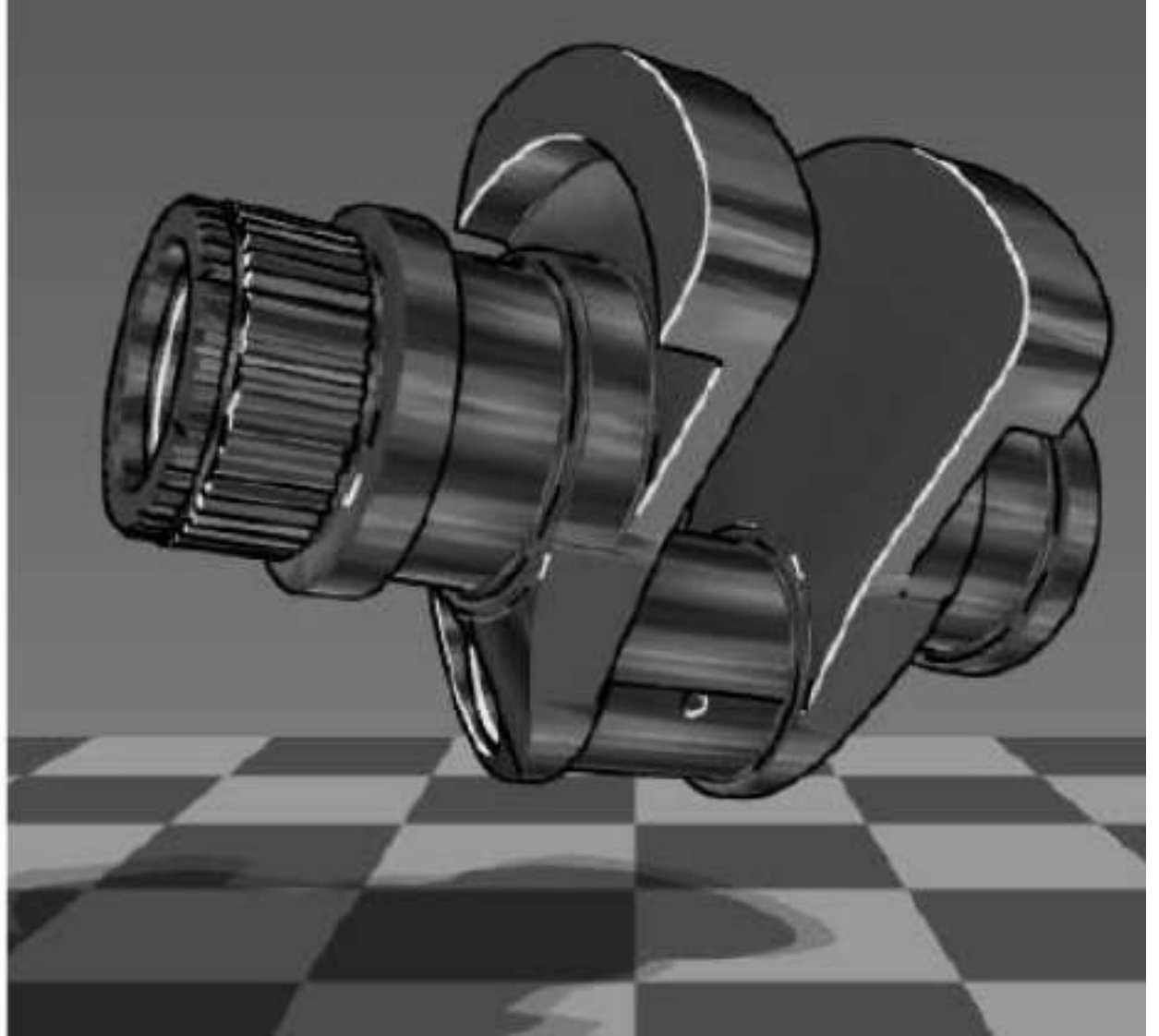
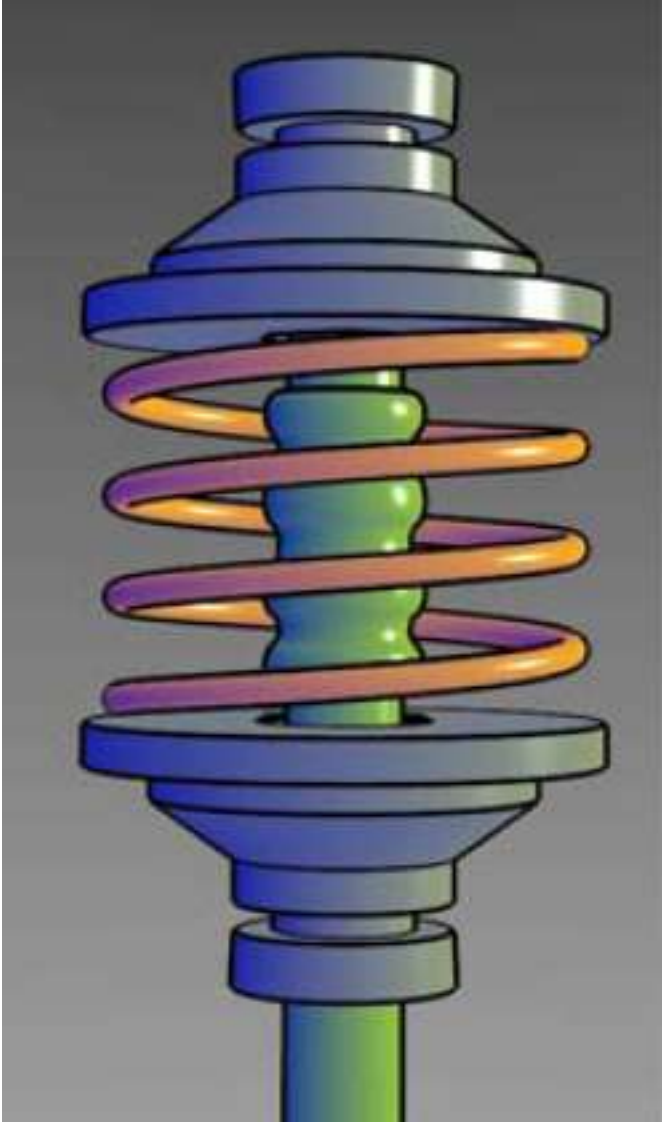

# Dalšie informácie

- T. Strothotte, S. Schlechtweg: Non-Photorealistic Computer Graphics
- B. Gooch, A. Gooch: Non-Photorealistic Rendering
- dostupný software: Adobe, Corel, GIMP ...
- [www.SIGGRAPH.org](http://www.SIGGRAPH.org), internet:
  - <http://www.red3d.com/cwr/npr/>
  - <http://www.cs.utah.edu/npr/>
  - [www.google.com](http://www.google.com)